

# LOCKER CH 2/4 1800/600/500

---

- |   |     |                         |
|---|-----|-------------------------|
| 1 | SK  | Montážny návod          |
| 2 | CZ  | Montážní návod          |
| 3 | DE  | Montageanleitung        |
| 4 | ENG | Assembly instructions   |
| 5 | PL  | Instrukcja montażu      |
| 6 | RO  | Instrucțiuni de montaj  |
| 7 | IT  | Istruzioni di montaggio |

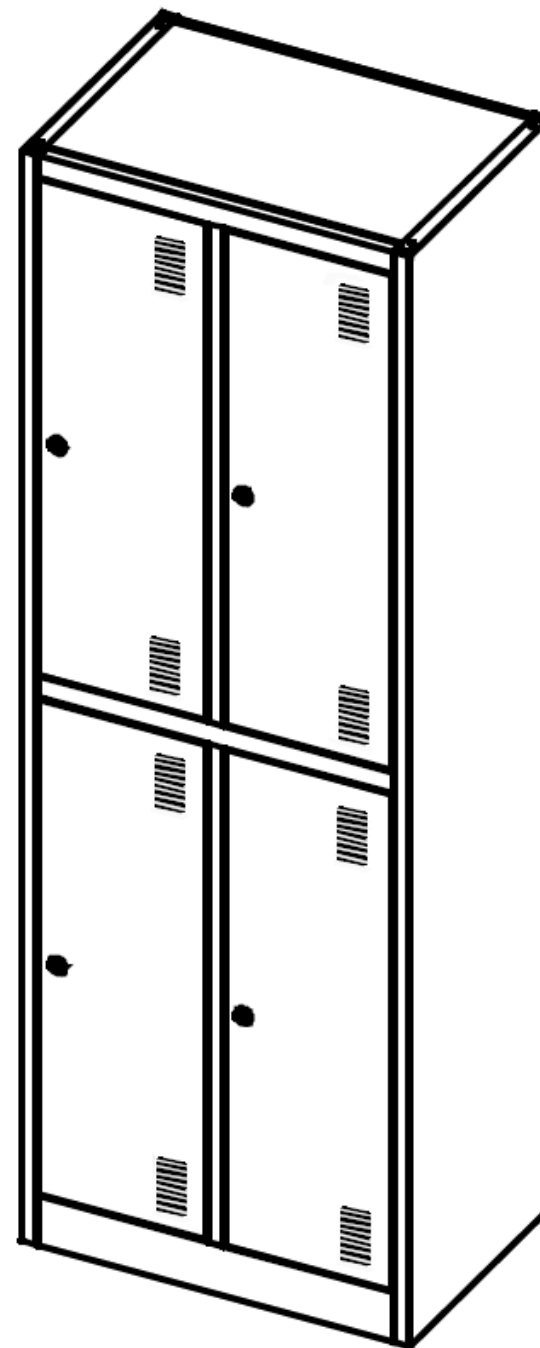



Lavá strana: 1 ks



Pravá strana: 1 ks

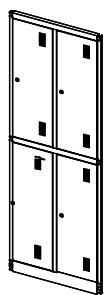

Rám dverí: 1 ks

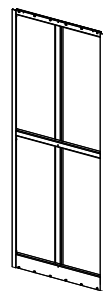

Zadná doska: 1 ks

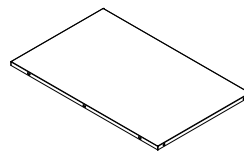

Vrchná doska: 1 ks

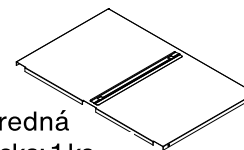

Stredná doska: 1 ks

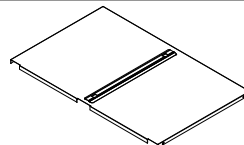

Spodná doska: 1 ks



Samorezné skrutky  
(5x10): 16 ks

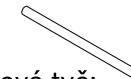

Vešiaková tyč:  
Ľavá (krátka) 2 ks  
Pravá (dlhá) 2 ks

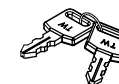

Kľúče: 4 sety

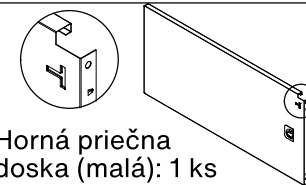

Horná priečna doska (malá): 1 ks

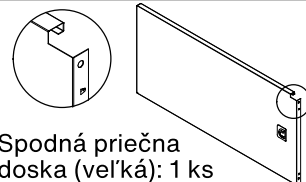

Spodná priečna doska (veľká): 1 ks

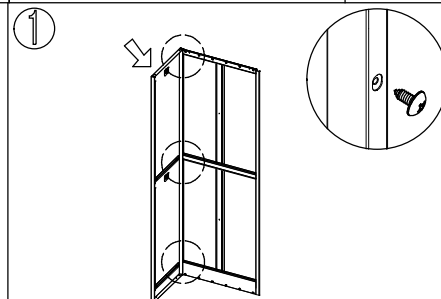
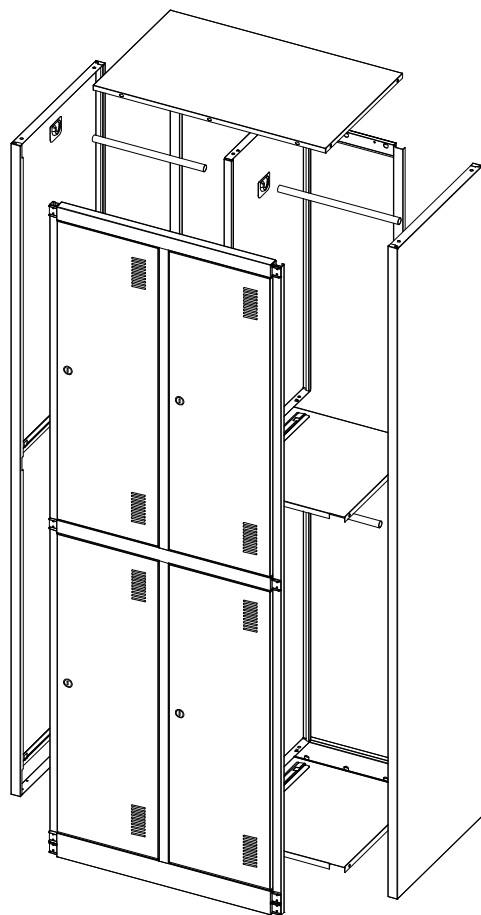

Priskrutkujte ľavú stranu a zadnú dosku samoreznými skrutkami (5x10)

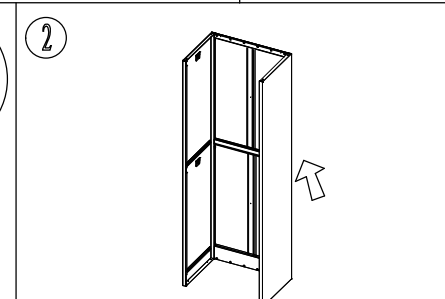

Pravú stranu priskrutkujte k zadnej doske rovnakým spôsobom ako v prvom kroku

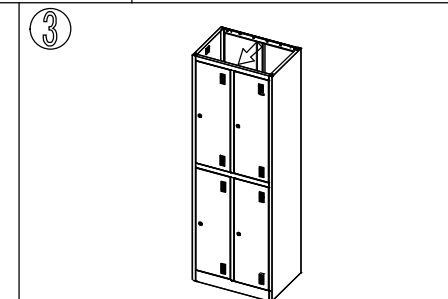

Upevnite zárubňu dverí do oboch bočných dosiek

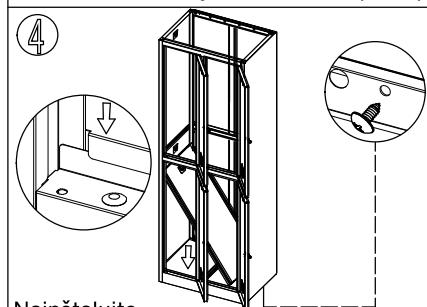

Nainštalujte spodnú dosku a potom rovnakým spôsobom nainštalujte spodnú deliacu dosku

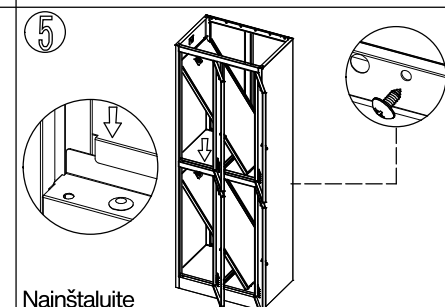

Nainštalujte strednú dosku a potom nainštalujte hornú deliacu dosku podľa výkresu.

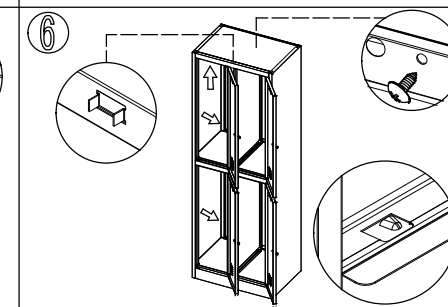

Nainštalujte hornú dosku a potom nastavte hornú a dolnú deliacu dosku, kým dobre nezapadajú.

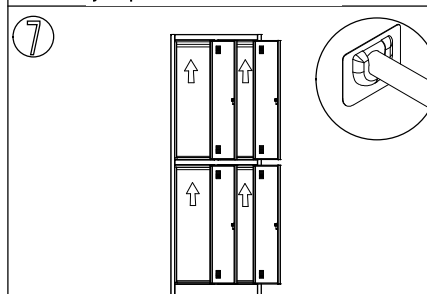

Nainštalujte závesnú tyč tak ako je označené.

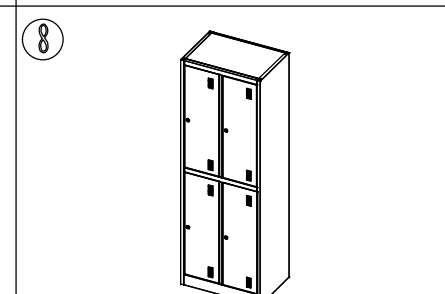

Po inštalácii upravte každú časť, aby dobre sedela.



Levá strana: 1 ks



Pravá strana: 1 ks

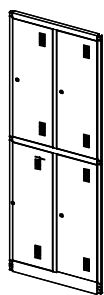

Rám dveří: 1 ks

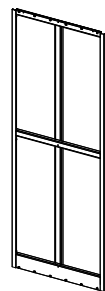

Zadní deska: 1 ks

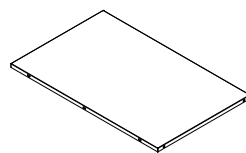

Vrchní deska: 1 ks

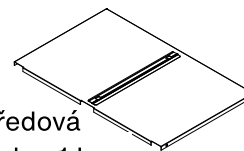

Středová deska: 1 ks

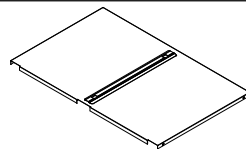

Spodní deska: 1 ks



Samořezné šrouby (5x10): 16 ks

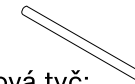

Věšáková tyč:  
Levá (krátká): 2 ks  
Pravá (dlouhá): 2 ks

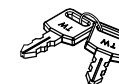

Klíče: 4 sady

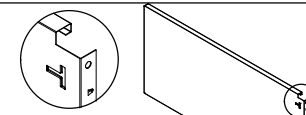

Horní příčná deska (malá): 1 ks

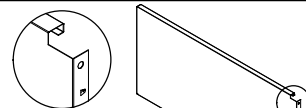

Spodní příčná deska (velká): 1 ks

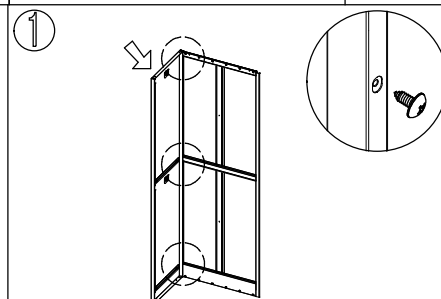
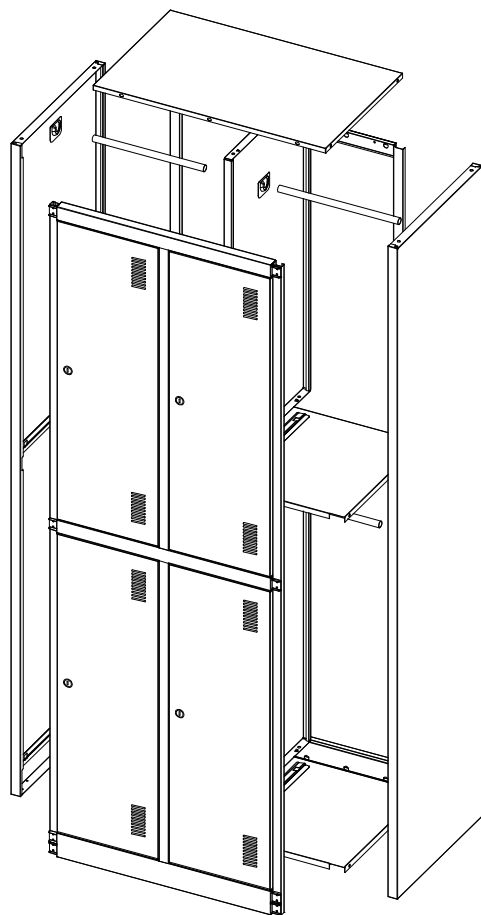

1  
Přišroubujte levou stranu a zadní desku samořeznými šrouby (5x10).

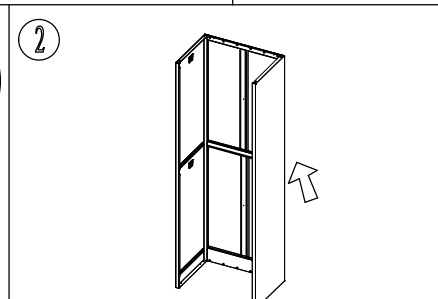

2  
Pravou stranu přišroubujte k zadní desce stejným způsobem jako v prvním kroku.

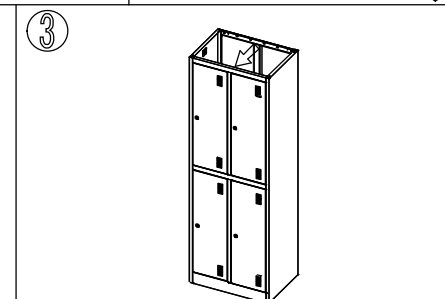

3  
Upevněte zárubeň dveří do obou bočních desek.

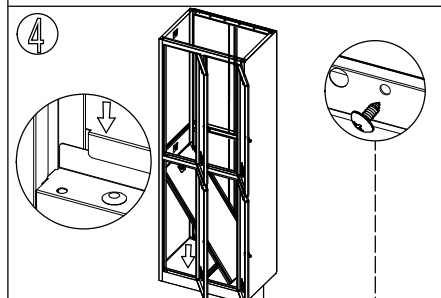

4  
Nainstalujte spodní desku a poté stejným způsobem nainstalujte spodní dělicí desku.

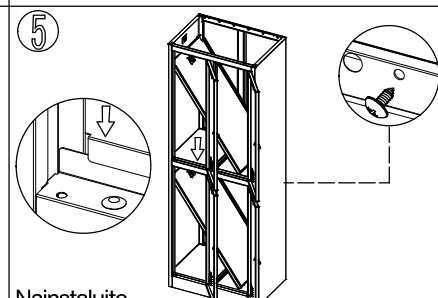

5  
Nainstalujte středovou desku a poté podle výkresu nainstalujte horní dělicí desku.

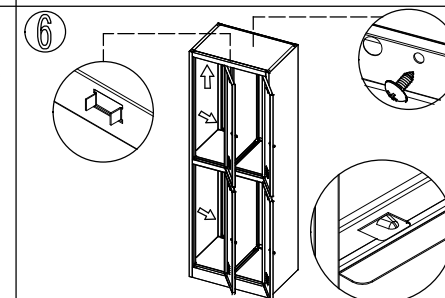

6  
Nainstalujte horní desku a poté nastavte horní a dolní dělicí desku tak, aby dobře zapadly.

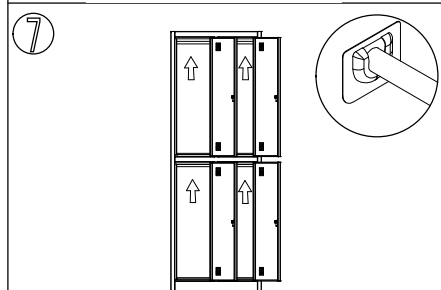

7  
Nainstalujte věšákovou tyč podle označení.

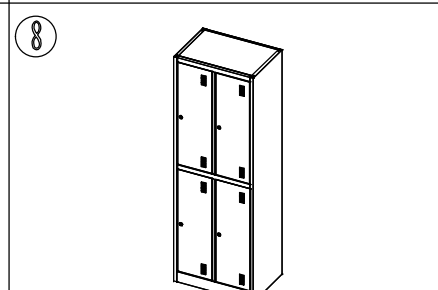

8  
Po instalaci upravte každou část tak, aby dobře seděla.



Linke Seite: 1 Stk.



Rechte Seite: 1 Stk.

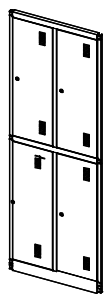

Türrahmen: 1 Stk.

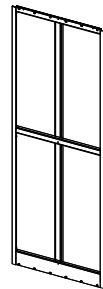

Rückwand: 1 Stk.

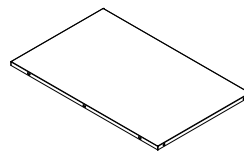

Obere Platte: 1 Stk.

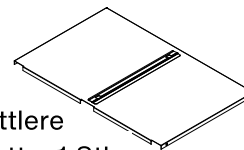

Mittlere Platte: 1 Stk.



Kleiderstange:  
Links (kurz): 2 Stk.  
Rechts (lang): 2 Stk.

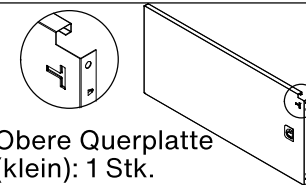

Obere Querplatte  
(klein): 1 Stk.

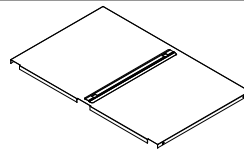

Bodenplatte: 1 Stk.



Selbstschneidende  
Schrauben (5x10): 16 Stk.



Schlüssel: 4 Sets

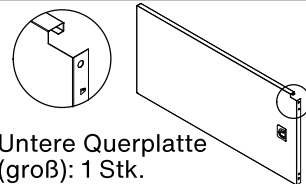

Untere Querplatte  
(groß): 1 Stk.

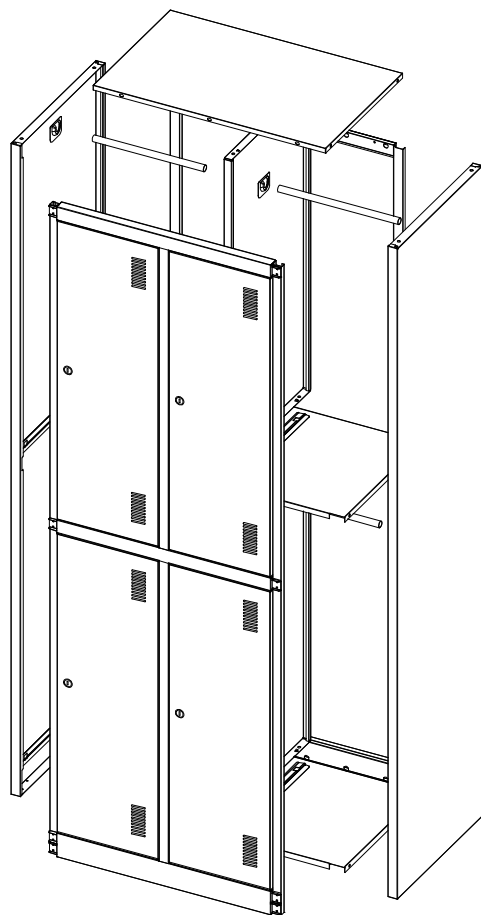

①

Schrauben Sie die linke Seite und die Rückwand mit selbstschneidenden Schrauben (5x10) zusammen.

②

Befestigen Sie die rechte Seite auf die gleiche Weise wie im ersten Schritt an der Rückwand.

③

Befestigen Sie den Türrahmen an beiden Seitenplatten.

④

Montieren Sie die Bodenplatte und danach auf die gleiche Weise die untere Trennplatte.

⑤

Montieren Sie die mittlere Platte und danach gemäß der Zeichnung die obere Trennplatte.

⑥

Montieren Sie die obere Platte und richten Sie anschließend die obere und untere Trennplatte so aus, dass sie gut sitzen.

⑦

Montieren Sie die Kleiderstange wie markiert.

⑧

Passen Sie nach der Montage alle Teile so an, dass sie gut sitzen.



Left side: 1 pc



Right side: 1 pc

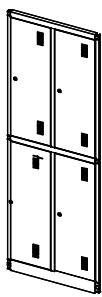

Door frame: 1 pc

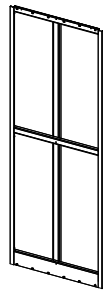

Back plate: 1 pc

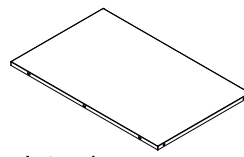

Top plate: 1 pc

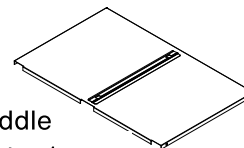

Middle plate: 1 pc



Hanging rod:  
Left (short): 2 pc  
Right (long): 2 pc

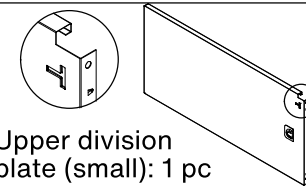

Upper division plate (small): 1 pc

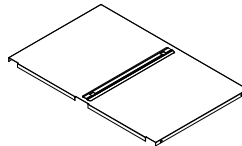

Bottom plate: 1 pc



Self-tapping screw  
(5x10): 16 pcs



Key: 4 sets

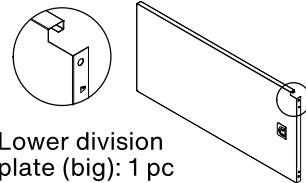

Lower division plate (big): 1 pc

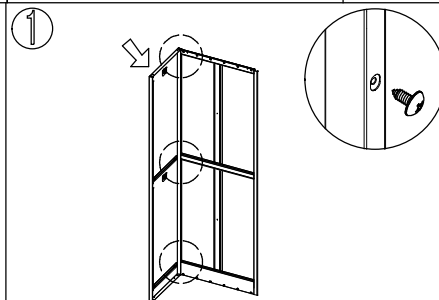
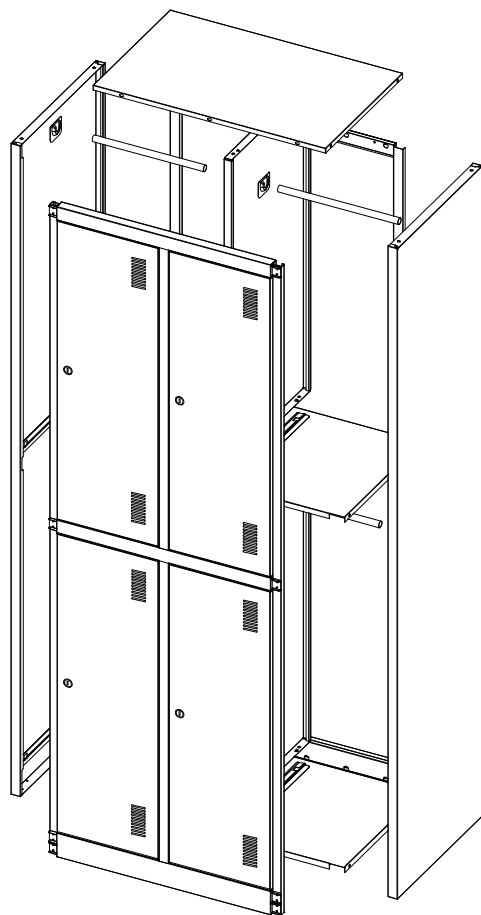

1 Bolt the left side and back plate with self-tapping screws (5x10).

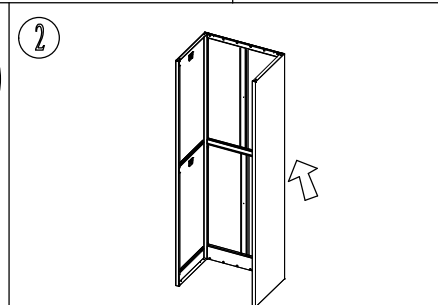

2 Bolt the right side with back plate in the same way as the first step.

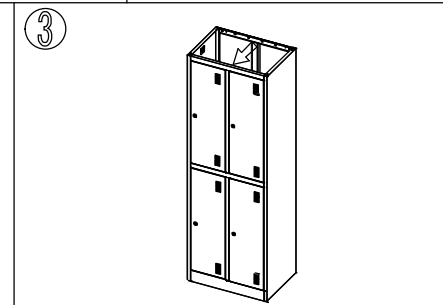

3 Fix the door frame onto both of the side plates.

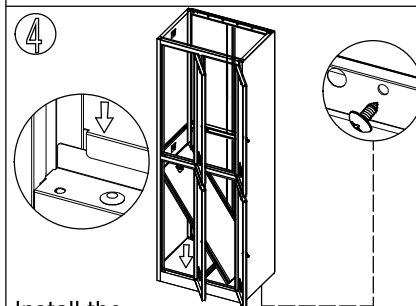

4 Install the bottom plate, then install the lower division plate in the same way.

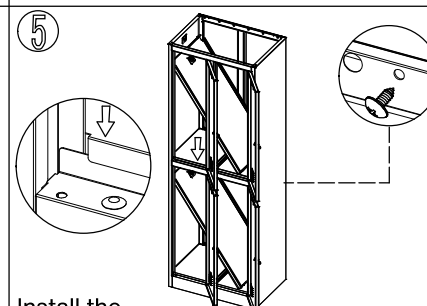

5 Install the middle plate, then install the upper division plate as the drawing.

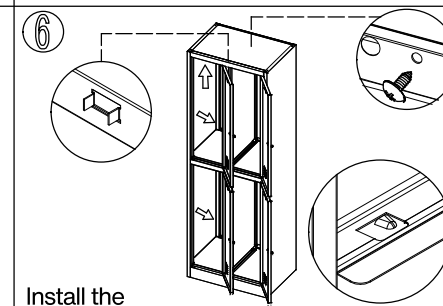

6 Install the top plate, then adjust the upper and lower division plate till fit well.

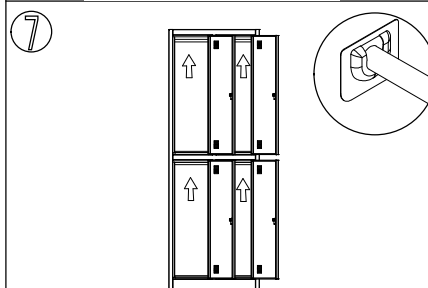

7 Install the hanging rod as the sign.

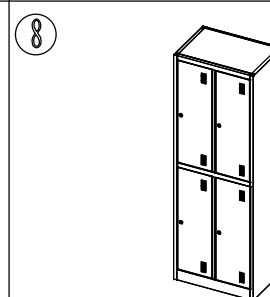

8 Adjust each part till fit well after installation.



Lewa strona: 1 szt.



Prawa strona: 1 szt.

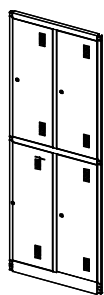

Rama drzwi: 1 szt.

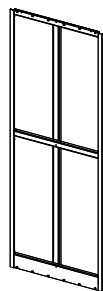

Tylna płyta: 1 szt.

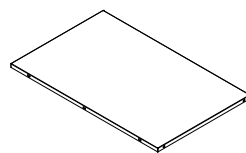

Górna płyta: 1 szt.

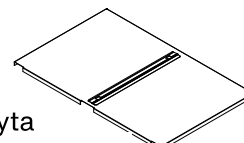

Płyta  
środkowa: 1 szt.

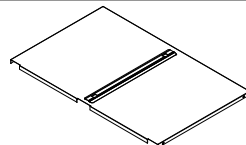

Dolna płyta: 1 szt.



Wkręty samogwintujące  
(5x10): 16 szt.

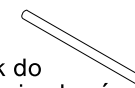

Drażek do  
wieszania ubrań:  
Lewy (krótki): 2 szt.  
Prawy (długi): 2 szt.

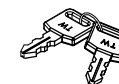

Klucze: 4 zestawy

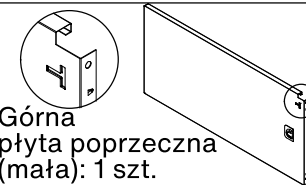

Górna  
płyta poprzeczna  
(mała): 1 szt.

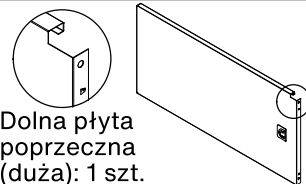

Dolna płyta  
poprzeczna  
(duża): 1 szt.

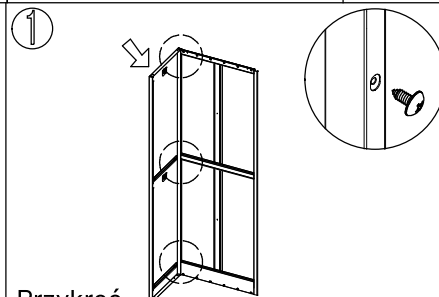
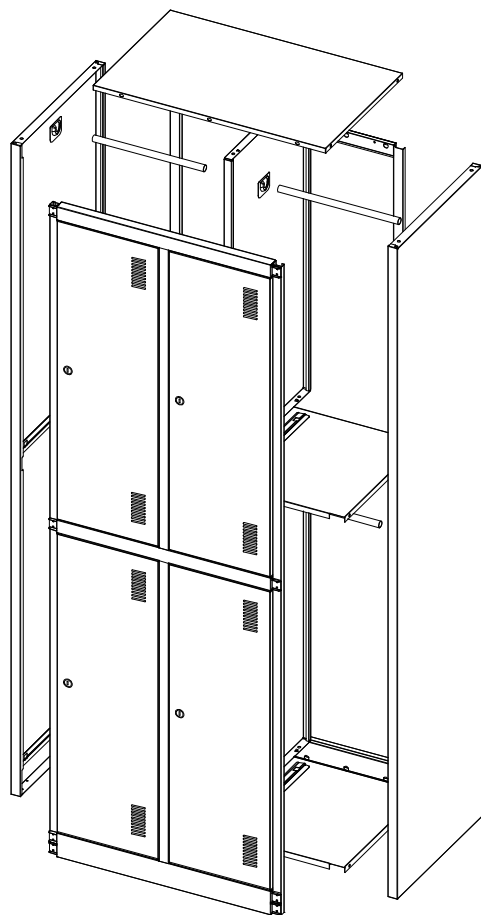

1  
Przykręć  
lewą stronę i tylną płytę za pomocą  
wkrętów samogwintujących (5x10).

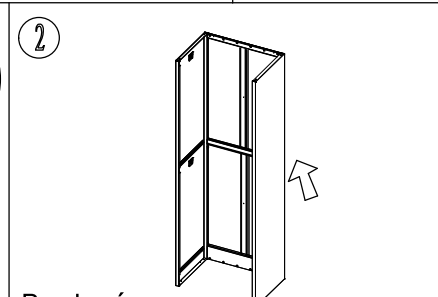

2  
Przykręć  
prawą stronę do tylnej płyty w taki  
sam sposób jak w pierwszym kroku.

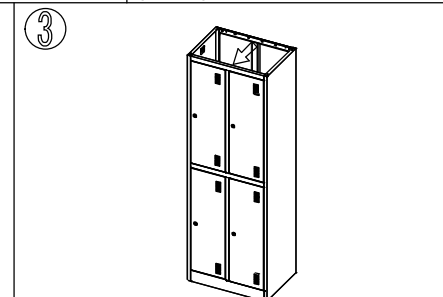

3  
Przymocuj ościeżnicę drzwi do  
obu bocznych płyt.

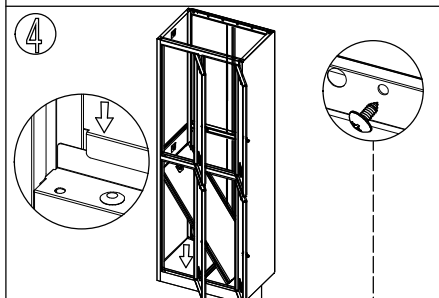

4  
Zamontuj  
dolną płytę, a następnie w ten sam  
sposób zamontuj dolną płytę dzielącą.

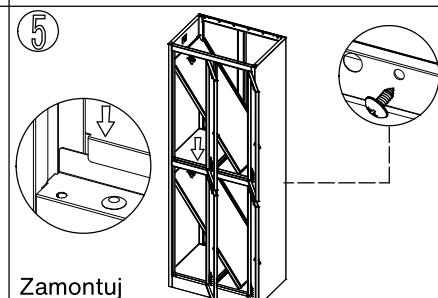

5  
Zamontuj  
płytę środkową,  
a następnie zgodnie z rysunkiem  
zamontuj górną płytę dzielącą.

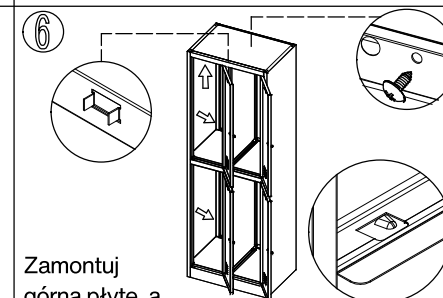

6  
Zamontuj  
górną płytę, a  
następnie wyreguluj górną i dolną płytę  
dzielącą, aż będą dobrze dopasowane.

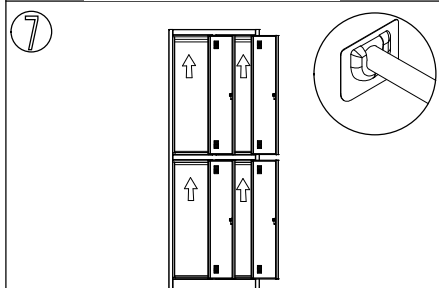

7  
Zamontuj  
drażek zgodnie z oznaczeniem.

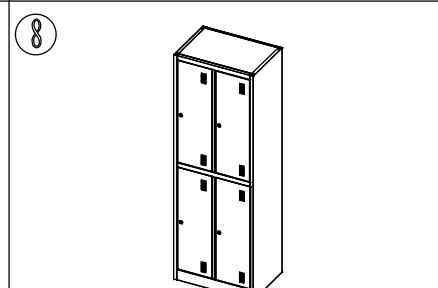

8  
Po montażu wyreguluj każdą część, aby dobrze pasowała.

PL

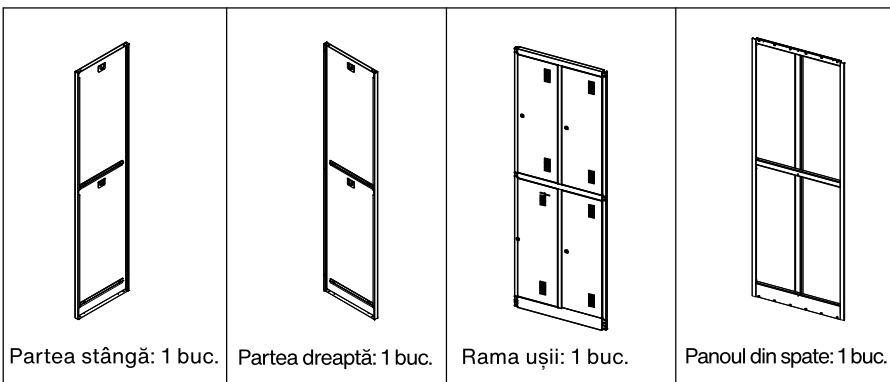

Partea stângă: 1 buc.

Partea dreaptă: 1 buc.

Rama uşii: 1 buc.

Panoul din spate: 1 buc.

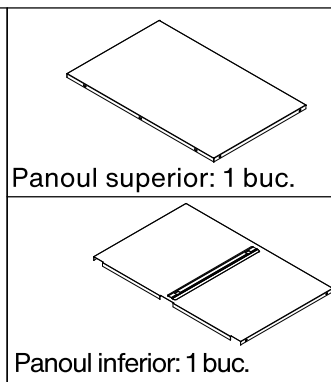

Panoul superior: 1 buc.

Panoul inferior: 1 buc.

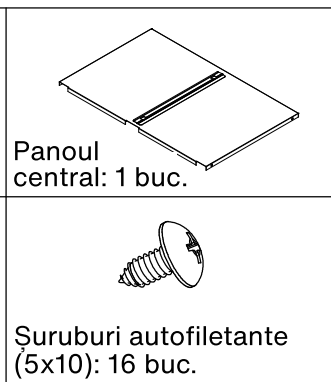

Panoul central: 1 buc.

Şuruburi autofiletante (5x10): 16 buc.

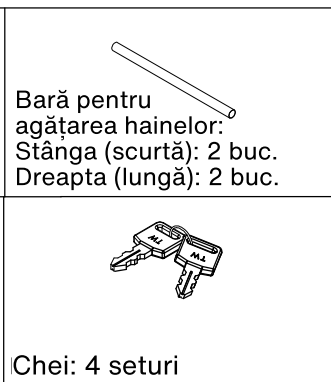

Bară pentru agăţarea hainelor:  
Stânga (scurtă): 2 buc.  
Dreapta (lungă): 2 buc.

Chei: 4 seturi

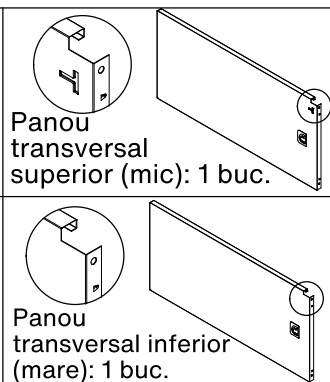

Panou transversal superior (mic): 1 buc.

Panou transversal inferior (mare): 1 buc.

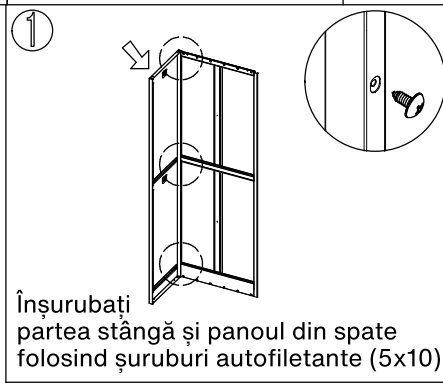
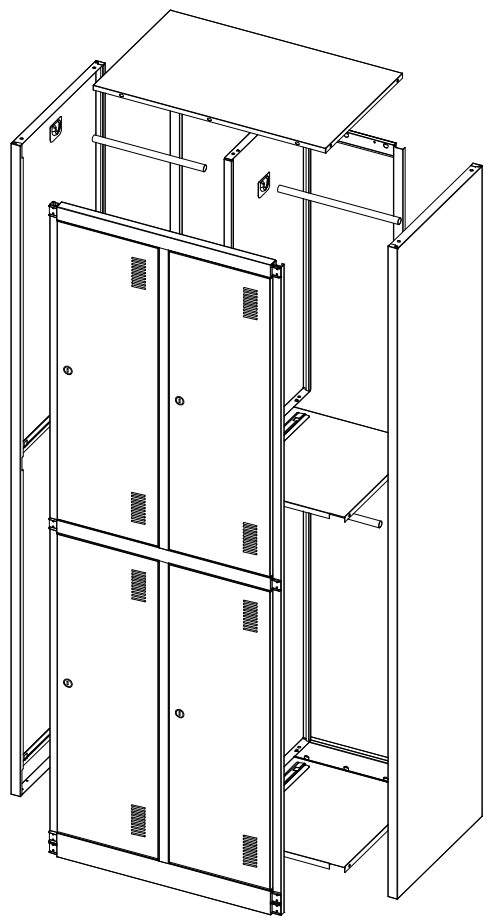

1  
Înşurubaţi partea stângă şi panoul din spate folosind şuruburi autofiletante (5x10).

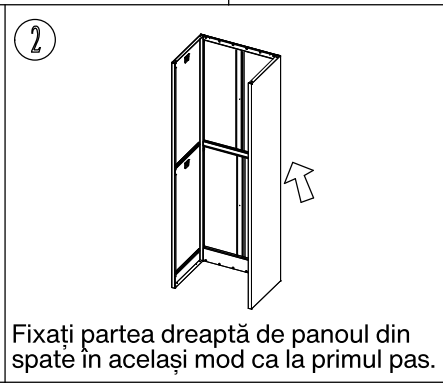

2  
Fixaţi partea dreaptă de panoul din spate în acelaşi mod ca la primul pas.

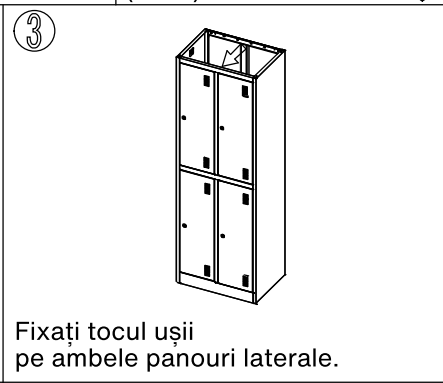

3  
Fixaţi tocul uşii pe ambele panouri laterale.

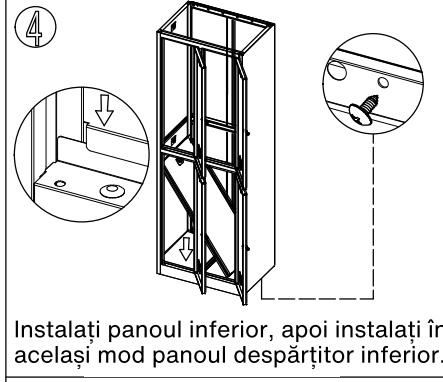

4  
Instalaţi panoul inferior, apoi instalaţi în acelaşi mod panoul despărţitor inferior.

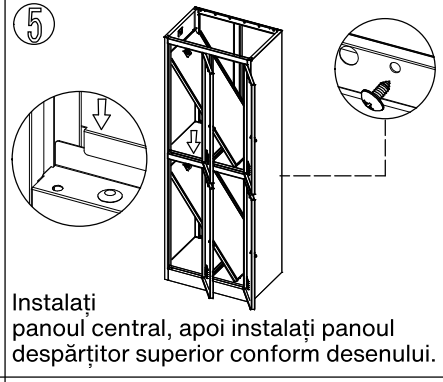

5  
Instalaţi panoul central, apoi instalaţi panoul despărţitor superior conform desenului.

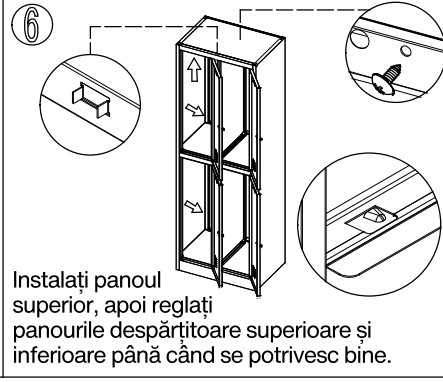

6  
Instalaţi panoul superior, apoi reglaţi panourile despărţitoare superioare şi inferioare până când se potrivesc bine.

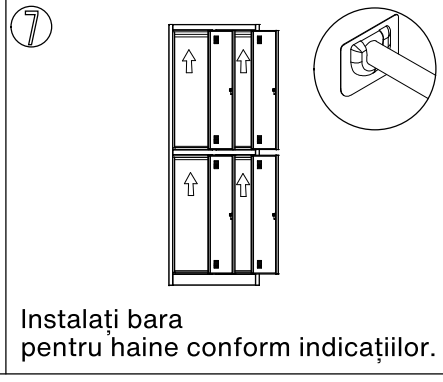

7  
Instalaţi bara pentru haine conform indicaţiilor.

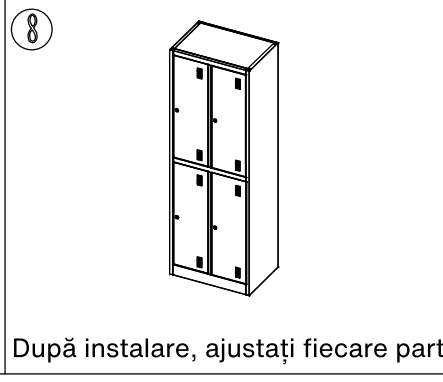

8  
După instalare, ajustaţi fiecare parte astfel încât să se potrivească bine.

Lato sinistro: 1 pz	Lato destro: 1 pz	Telaio della porta: 1 pz	Pannello posteriore: 1 pz	Pannello inferiore: 1 pz	Viti autofilettanti (5x10): 16 pz	Chiavi: 4 set	Pannello trasversale inferiore (grande): 1 pz

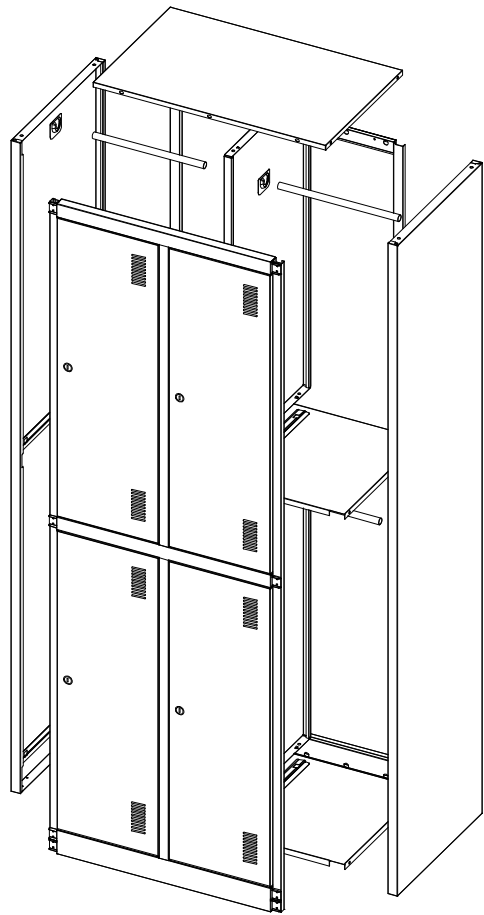

<p>①</p> <p>Avvitare il lato sinistro e il pannello posteriore utilizzando le viti autofilettanti (5x10).</p>	<p>②</p> <p>Fissare il lato destro al pannello posteriore nello stesso modo del primo passaggio.</p>	<p>③</p> <p>Fissare il telaio della porta a entrambi i pannelli laterali.</p>
<p>④</p> <p>Installare il pannello inferiore e successivamente installare nello stesso modo il pannello divisorio inferiore.</p>	<p>⑤</p> <p>Installare il pannello centrale e poi installare il pannello divisorio superiore secondo il disegno.</p>	<p>⑥</p> <p>Installare il pannello superiore e quindi regolare i pannelli divisori superiore e inferiore finché non si adattano correttamente.</p>
<p>⑦</p> <p>Installare la barra appendiabiti come indicato.</p>	<p>⑧</p> <p>Dopo l'installazione, regolare ogni parte in modo che si adatti correttamente.</p>	